

Rewinding and Slitting machine type UW ***Umwickel- und Schneidemaschine Typ UW***



This machine is built especially for cutting and rewinding a big amount of foil. The machine is typically used by foil distributors or end-users, who need to convert jumbo reels on 1 or 3 inch cores.

Diese Maschine eignet sich besonders um grosse Mengen an Folie zu schneiden und umzuwickeln. Die Maschine ist beliebt bei Folienhändlern und Endverbrauchern, die Jumbo Rollen auf 25mm oder 75mm Hülsen umspulen und schneiden müssen.

Layout
 Skizze

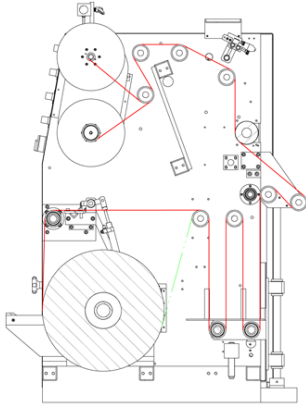

Slit and spool on
 3 inches cores
*Schneiden und auf 75mm
 Hülsen wickeln*



Spooling 1 inch
 master roll
*Stammrollen auf 25m
 Hülsen wickeln*



Technical specifications

Foil width:

UW 800	max. 31,4 in
UW 1000	max. 39,3 in
UW 1300	max. 51,1 in

Jumbo unwind:

Jumbo core Ø	3 + 6 in
Outside foil Ø	max. 21,6 in

Rewind:

Rewind core Ø	1 + 3 in
Outside foil Ø	max. 11 in

Speed:

max. 59 ft/min.

Foil tension: (Variable)

max. 200 N
 min. 10 N

Technische Merkmale

Folienbreite:

UW 800	max. 800 mm
UW 1000	max. 1'000 mm
UW 1300	max. 1'300 mm

Jumbo Abrollung:

Innen Ø	3 + 6 Zoll
Aussen Ø	max. 550 mm

Aufwicklung:

Innen Ø	1 + 3 Zoll
Aussen Ø	max. 280 mm

Wickelgeschw.:

max. 180 m/Min.

Folienzug: (Stufenlos)

max. 200 N
 min. 10 N

Optional extras / Sonderzubehör (optional)

foil clamping
 at foil stop
*Folienklemme bei
 Maschinenstop*

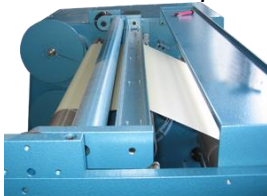

Spread roller
 (banana roller)
Breitstreckwalze



Front splice table
*Spleisstisch mit
 Umlenkwalze*



Linear double
 knife unit
*Lineare Doppel-
 messereinheit*

